

installation of PE pipelines for water and gas

The polyethylene differs from traditional materials used for pipelines carrying fuel gas and fluids under pressure for its particular physical and mechanical characteristics of high flexibility. If in the past these characteristics were considered a performance limit the same are now an advantage allowing the laid pipelines to support the ground stress.

If the laying and covering conditions are controlled, especially for the **ground compressing**, the use of PE pipes allow a greater network safety in case of ground settlements, landslides or earthquakes. Furthermore the PE pipelines flexibility allow the use of innovative laying technologies with important reduction in times and laying network costs. The PE lightweight and the easy weldability give advantages in terms of speed of the laying operations.

Laying bed

The bottom of excavation must be flat in order to give regular holding to the pipeline, made of uniform materials and without sharp elements which can damage the pipe. The **height of the laying bed** must be of **100 – 150 mm**.

installation

Installation procedures must be performed by expert Operators.

For pipe installation follow the exact position according to the project drawings (altimetrical and planimetrical) unless otherwise suggested by the Works Supervisor.

To put inside the trench the single pipelines made outside the excavation use hemp/synthetic ropes avoiding possible scraping on the ground or on the excavation edge. Pipe section with surface cuts exceeding 10% of their thickness must be cutted off.

Control devices such as valves and gate valves which can stress the pipes due to their weight must be hold by independent supports avoiding any stress on the pipeline and joints.

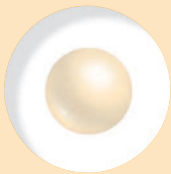

filling up

Once pipes laid in the excavation, they must be covered by a sand layer having height within **100 and 300 mm** measured from the upper pipe generatrix. Special care must be used when compacting the layer up to about $\frac{2}{3}$ rds of the pipe height. Compacting must be manually done avoiding any pipe movement.

Compacted sand must be of good consistency and uniformity covering both sides of the pipe.

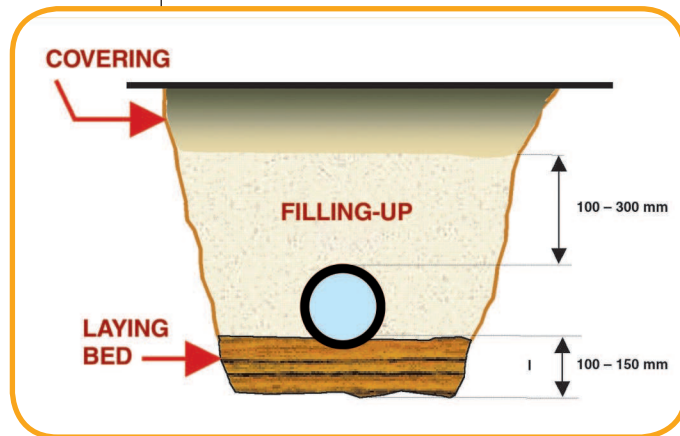

covering

If the pipe is tightened at its ends before the filling-up of excavation, it is forced by remarkable stress due to its thermic expansion, so it is necessary to proceed as follows:

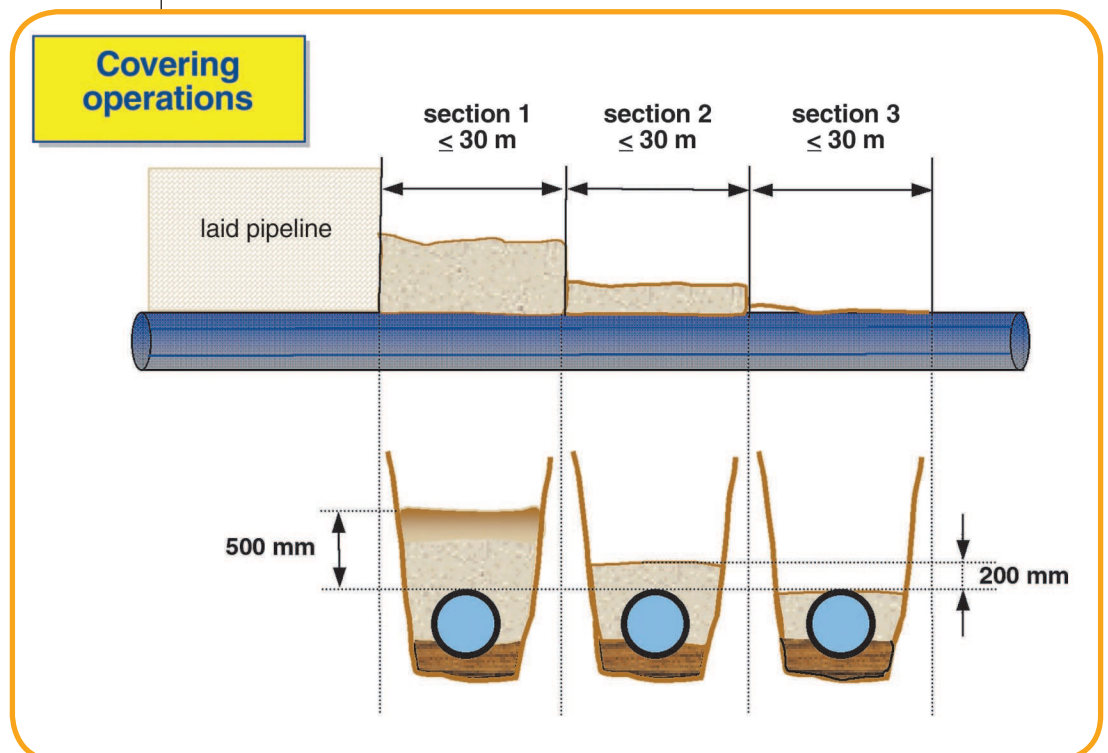

- the covering must be carried out on the whole network with the same ambient temperature conditions and if possible during the cool hours of the day;
- always proceed with sections of 20 – 30 meters and in one direction, possibly uphill;
- it is recommended to work at the same time on three pipeline sections for a total length of 90 meters;
- the covering on the three sections is done up to the top of the pipe (the pipe is covered with a sand layer of 100 mm at least);
- the first two sections are covered with further 15 – 20 cm of materials without stones;
- the first section is completely filled-up and covered up to 500 mm over the pipe;
- afterwards the covering of the second section is done and subsequently up to the complete covering of the network.

signals

A continuous yellow colored strip must be installed during the covering works with the message “Attention Gas Pipe” or blue colored with “Attention Water Pipe”. This strip is laid at **300 mm** over the upper generatrix of the pipeline indicating the pipe presence for future excavation works. Whenever other services are being installed, the new excavation must never show the sand which covers the pipeline.

If pipeline detection systems are used such as Ball Markers, these must be fixed on the pipeline by plastic clamps in order to keep them axially aligned.

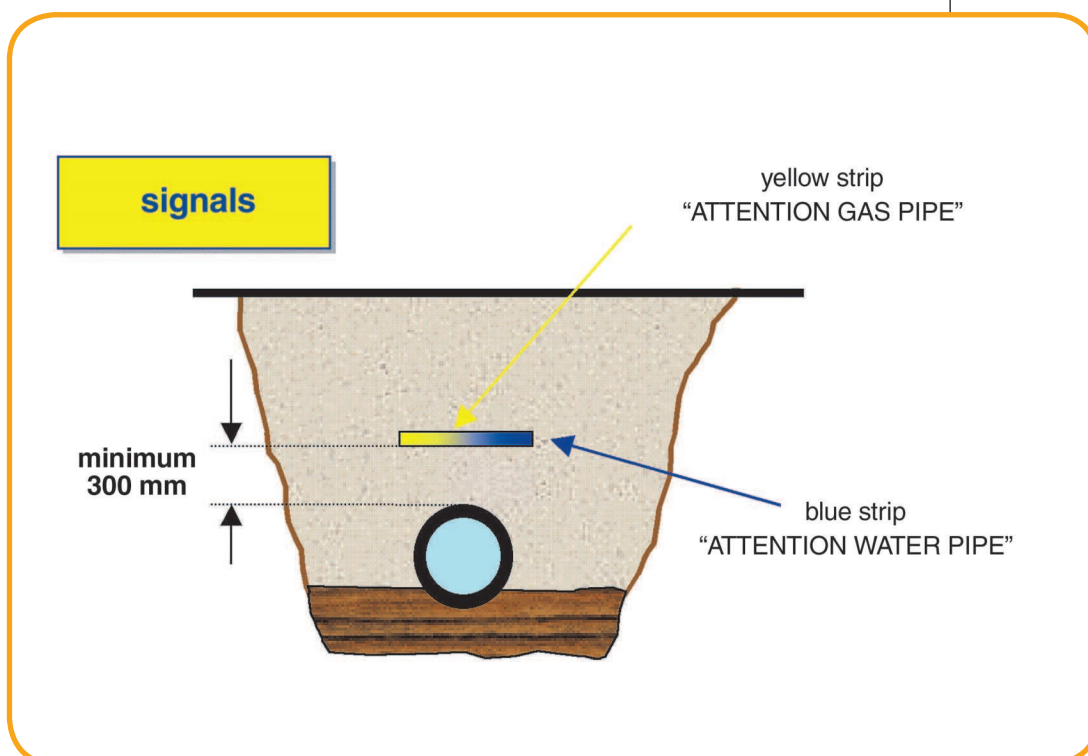

gas pipelines

gas pipeline classification

The DM 24.11.1984 and the standard UNI 9165 classify the polyethylene pipelines for fuel gas transport in the following **types**, characterized by different max working pressure values:

pipeline type	series S	SDR	working conditions
7 th	12,5	26	max 0,04 bar
6 th	12,5	26	max 0,5 bar
5 th	12,5	26	max 1,0 bar
5 th	8	17	max 1,5 bar
4 th	5	11	max 5,0 bar

pipeline plan

The pipelines carrying fuel gas must be buried. The minimum burial **depth** is measured from the upper generatrix of the pipe at ground level and depends from the pipeline type and laying area conditions as reported in the following table. The PE pipes laying outside ground is not allowed, except for the end part of branch line which must be suitably protected.

laying area	pipeline type		notes
	4 th & 5 th	6 th & 7 th	
Roadway	0,90 m	0,60 m	
Area without vehicle traffic: flowerbeds, pavements, traffic islands, city green area	0,40 m	0,40 m	Only if the pipeline is laid at least 0,50 m from roadway border
Country land	0,90 m	0,60 m	A smaller depth (with minimum of 0,50 m) is allowed near to undulations, drainage ditch, bumps
Rocky soil	0,40 m	0,40 m	

distance from buildings

The safety distance from buildings depends on the pipeline type, density of carried gas and laying conditions as reported in the following table:

laying class		pipeline type		
class	description	4 th & 5 th		6 th & 7 th
		density < 0,8	density > 0,8	
A	Soil with superficial waterproof surface, as asphalt, stone slabs, cement and other natural or artificial coverings. The soils with a high permeability in its deepness are included within this category.	2 m	2 m	No prescription
B	Soil without a superficial waterproof surface provided that this condition exists for a layer of at least 2 m and coaxial to the pipeline. The soils with a low or equal permeability at trench digging are included within this category.	1 m	2 m	
C	Soil within category A where is necessary the gas drainage by building-up over the pipeline and along its axis a higher permeability area, suitable to the pipeline diameter by using gravel, hollow bricks and similars. It is also necessary to place within this area breather devices positioned at a max distance of 150 m one each other and protected against obstruction.	1 m	Laying not allowed	
D	Pipeline inserted in pipes or special devices closed in walling or cement, on which must be placed shutters and breathers at suitable distance. These devices must be built-up using pipes with inside diameter not smaller than 30 mm and positioned at a max distance of 150 m one each other and protected against obstruction.	No prescription	No prescription	

cross-service interferences

UNDERGROUND SERVICES

The following table summarizes the values of distance measured between both facing surfaces in case of parallel routes, overpasses and underpasses of existing pipelines for different uses (underground shaft for electrical and phone cables, sewerage system and similar):

pipeline type	minimum distance between facing surfaces
4 th	0,50 m
5 th	0,50 m
6 th	enough to allow possible maintenance on both underground pipelines
7 th	

If it is not possible to respect the minimum distance of 0,50 m for pipelines of 4th and 5th type, the gas pipeline must be fitted inside a protective pipe. In case of crossing the ends must be extended for at **least 1 meter** near to the overpass and **3 meters** near to the underpass measured from the vertical tangents to the external existing pipeline walls.

In case of parallelism between pipelines for transport of gas with **density < 1 kg/m³** (i.e. methane) with sewerage system, the first must be laid at a superior level in the way that the lower generatrix of the gas pipeline will be laid at the same level of the upper generatrix of the sewerage pipe, but on a different vertical position.

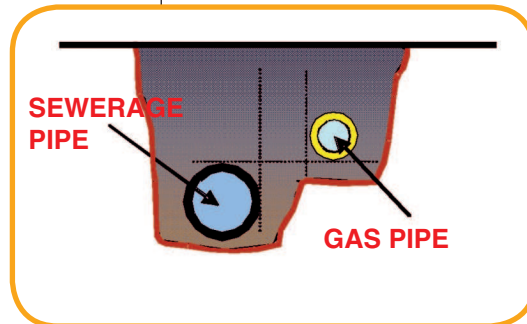

gas (methane) pipeline with $\rho < 1 \text{ kg/m}^3$

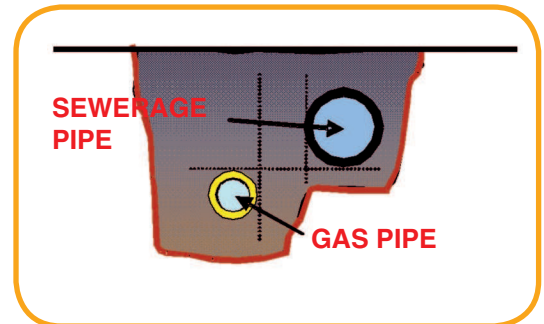

gas (LPG) pipeline with $\rho > 1 \text{ kg/m}^3$

Opposite are the regulation for parallelism between pipelines for transport of gas with **density > 1 kg/m³** (i.e. LPG) with sewerage system. For parallelism longer than 150 meters it is necessary to provide compensators and breather devices.

CITY TRAMWAY LINES

In case of **parallel routes to urban tramlines** the minimum distance horizontally measured between the external pipeline surface and the nearest rail **cannot be less than 0,50 m**.

In case of **crossing city tramway lines** the laying pipeline depth cannot be **less than 1 meter** measured between the upper generatrix of the pipeline itself and the rail track. The pipelines of 4th and 5th type must be fitted in a **protective pipe**. In case of crossing the ends must be extended for at least **1 meter** measured starting from the outside rail. For pipelines of 6th and 7th type is possible an inferior laying depth anyway **not less than 0,50 m**.

RAILWAY LINES

Special regulations issued by Transport Ministry are applied in case of parallelism and crossing of railway lines and suburban tramway lines.

excavation

Excavation dimension are codified by the reference standard. The minimum **width at bottom of trench must be at least 20 cm** bigger than the diameter of the pipe to be laid.

pipe bending

To avoid excessively stress on the material, PE pipes in bars can be bended at the following bending radii (r). Forced heating are not allowed.

pipe class		minimum bending radius		
		laying temperature		
SDR	S	20°C	10°C	0°C
26	12,5	$r = 30 d_n$	$r = 45 d_n$	$r = 65 d_n$
17	8	$r = 20 d_n$	$r = 35 d_n$	$r = 50 d_n$
11	5	$r = 20 d_n$	$r = 35 d_n$	$r = 50 d_n$

In case of smaller bending radii it is necessary to use injection moulded or segment bends.

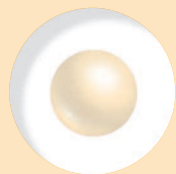

water pipelines

trench design

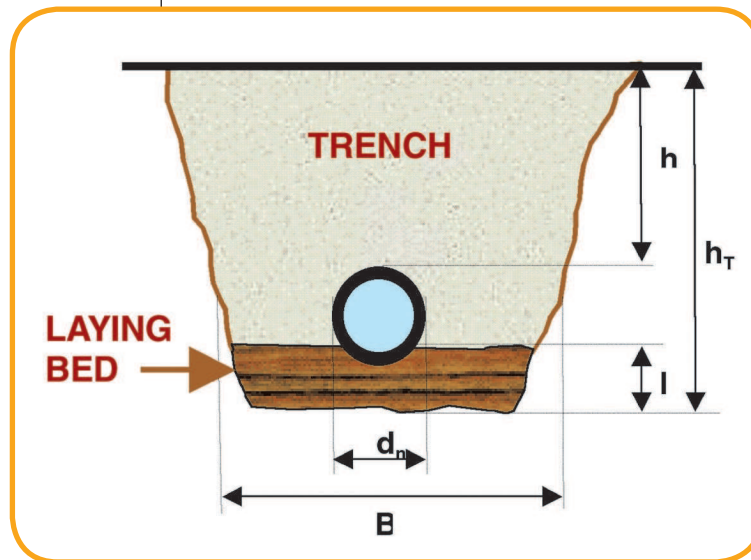

The minimum trench **width B** depends on the nominal diameter d_n of the pipe to be laid, as reported in the following table and according to the standard UNI 11149:2005:

diameter d_n [mm]	minimum width [mm]
≤ 315	$d_n + 400$
355 – 900	$d_n + 600$
1000 – 1600	$d_n + 800$
> 1600	$d_n + 1200$

Measures can be reduced if no personnel need work inside the trench. Pipeline must be laid near to the centre line of trench.

If trench must hold two or more pipeline systems, these must be laid at distance greater than 150 mm with respect to the used compressing equipment.

If the pipeline is subjected to road traffic the standard UNI 11149 states that the **minimum covering height h** must be equal to **1 meter** or of **1,2 meter** if subjected to railway or air traffic.

If trench depth is lower than the above-mentioned, the **pipe must be protected from external traffic loads** by use of proper reinforced-concrete slab positioned at a distance not lower than **300 mm** from the upper generatrix of the pipe.

parallelism and crossing

For underground crossing installation the pipeline must be fitted in a protective pipe suitably dimensioned according to DM 23.02.1971 (updated 10.08.2004) which provides that on the crossing the protection must be extended of at least **3 meters** measured from the farrest rail.

The minimum pipe covering height must be at least **1,2 meters**. The pipeline route must be perpendicular to the railway axis. If not possible, a crossing angle is admitted, anyway not lower than 45° . The crossing on railway groups with total width more than 20 meters is not allowed.

For the installation of **out-of-ground or aerial crossings** the pipeline must be fitted in a protective pipe suitably dimensioned according to DM 23.02.1971.

The installation of pipelines parallel to the railway must respect the minimum distance of 1 meter from the railway accessory area limit.

The installation of river crossings is allowed by using existing works such as bridges or tunnels.

For the installation of parallel networks or crossings with other pipelines, the new pipeline must be laid at a safety distance in order to guarantee the maintenance of all pipelines.

Once crossing/parallelism is completed, it is necessary to issue a **“regular execution report”** signed from the responsables which authorizes the applicant party to put in pressure the pipeline. Furthermore the applicant party must carry out all pipeline inspection with yearly frequency from its starting-up.

